

TRAVAIL DE HAUT RENDEMENT
- pour matières graphites -

Graphite / Grafite

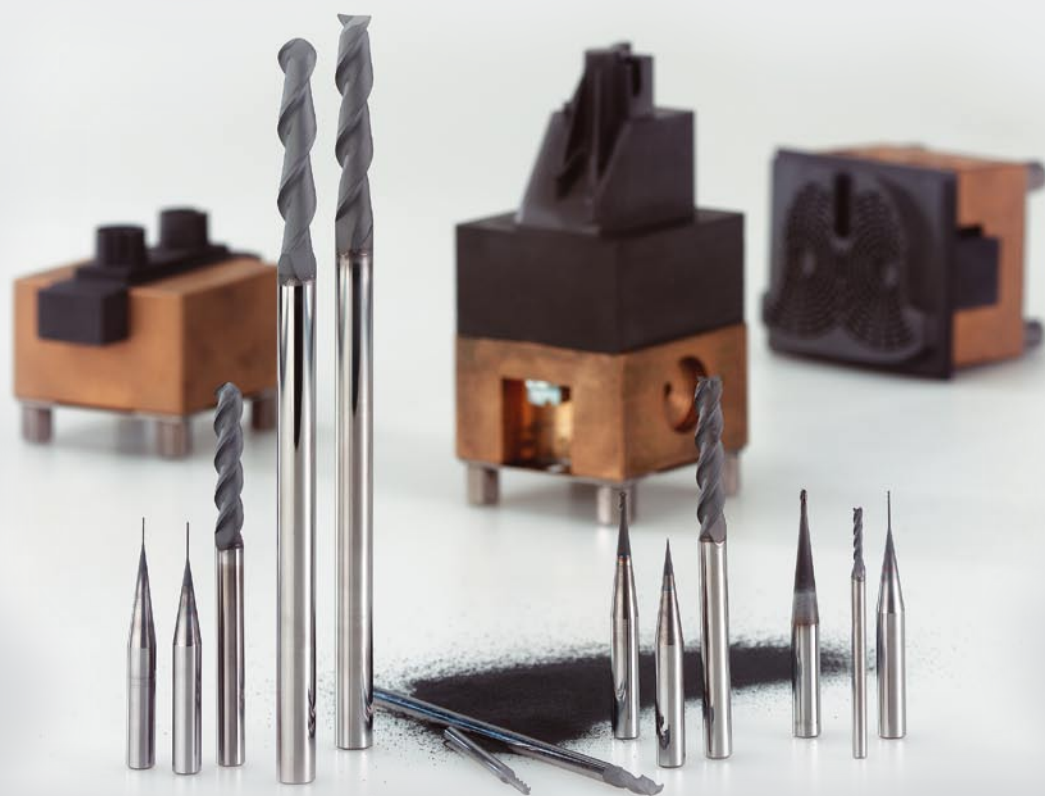

LAVORAZIONE ALTA VELOCITÀ
- su grafite -

Graphite
Grafite

	Type Tipo	Page Pag.
<p>Fraises Hémisphériques 2-/3-goujures</p> <p>Frese Sferiche 2-/3-taglienti</p>	DSKG	K14-K15
<p>Fraises toriques 2-/3-goujures avec Rayon d'angles</p> <p>Frese Toriche 2-/3-taglienti con Spigolo raggiato</p>	DSTG / DSTLG	K16-K18
<p>Fraises d'ébauche Frese per sgrossatura</p>	DSVG	K19
<p>Microfraises Hémisphériques 2-goujures avec Rayon d'angles</p> <p>Microfrese Sferiche 2-taglienti con Spigolo raggiato</p>	DSKMG / DSMMG	K20-K21
<p>Fomules Formule</p>		K57-K58
<p>Conditions de coupe Dati di taglio</p>		K66-K71

FRAISE HEMISPHERIQUE

FRESE SFERICA



pour graphite

per grafite

DSKG

3-lèvres, angle d'hélice 40°
3 taglienti, angolo d'elica 40°

recomm. conditions de coupe
page K67
Per parametri d'impiego suggeriti vd. pag. K66

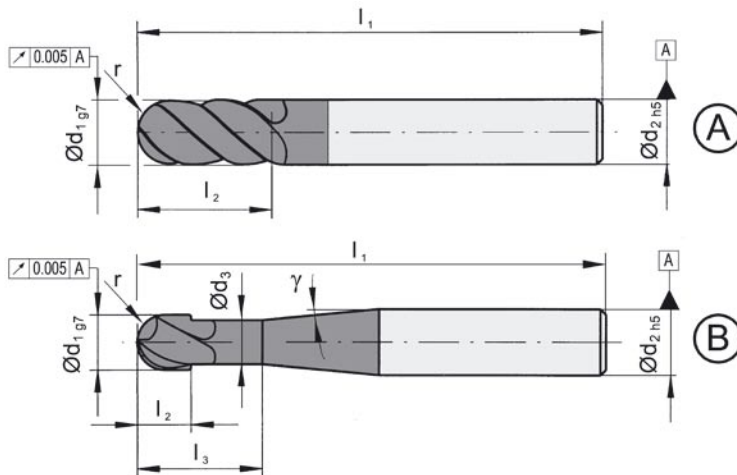

Standard
Serie standard

N° de commande Codice prodotto	d ₁	d ₂	d ₃	l ₁	l ₂	l ₃	r	Z	γ	Version Versione	CD5K
DSKG.3.06.77.06	6	6					3,0				•
DSKG.3.08.77.08	8	8					4,0				•
DSKG.3.10.77.10	10	10	-	77	32	-	5,0	3	-	A	•
DSKG.3.12.77.12	12	12					6,0				•
DSKG.3.02.50.04.L20	2	4	1,9	50	12	20	1,0				•
DSKG.3.02.63.06.L25	2	6	1,9	63	12	25	1,0				•
DSKG.3.03.50.04.L20	3	4	2,9	50	12	20	1,5				•
DSKG.3.03.63.06.L25	3	6	2,9	63	12	25	1,5	3	15°	B	•
DSKG.3.04.63.06.L30	4	6	3,8	63	16	30	2,0				•
DSKG.3.05.63.06.L30	5	6	4,8	63	22	30	2,5				•

Dimensions en mm
Dimensioni in mm

Nuance recommandée
Leghe consigliate

Revêtement diamant
Rivestite Diamond

FRAISE HEMISPHERIQUE

FRESE SFERICA



pour graphite

per grafite

DSKGL

2-lèvres, angle d'hélice 40°
2 taglienti, angolo d'elica 40°

recomm. conditions de coupe
page K66

Per parametri d'impiego suggeriti vd. pag. K67

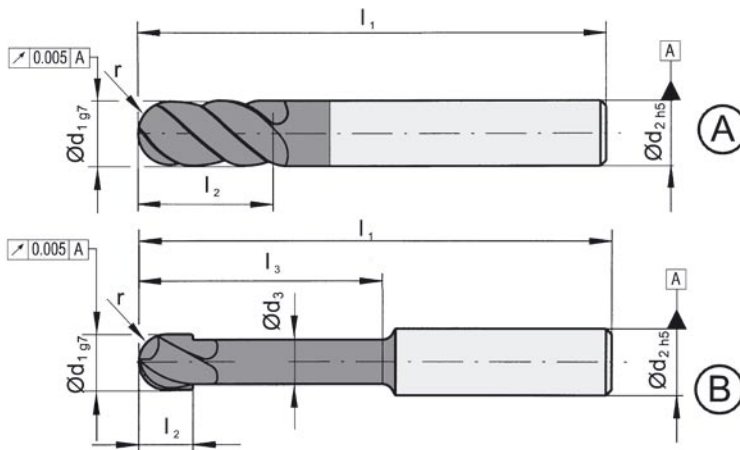

Série longue
Serie lunga

N° de commande Codice prodotto	d ₁	d ₂	d ₃	l ₁	l ₂	l ₃	r	Z	Version Versione	CD5K
DSKGL.2.06.099.06	6	6	5,6	99	20	45	3,0	2	A	•
DSKGL.2.08.149.08	8	8	7,6	149	20	60	4,0			•
DSKGL.2.10.149.10	10	10	9,6	149	20	75	5,0			•
DSKGL.2.12.149.12	12	12	11,6	149	25	75	6,0			•
DSKGL.2.02.099.04	2	4	1,9	99	5	10	1,0	2	B	•
DSKGL.2.03.099.04	3	4	2,9		8	15	1,5			•
DSKGL.2.04.099.06	4	6	3,8		15	30	2,0			•

Dimensions en mm
Dimensioni in mm

Nuance recommandée
Leghe consigliate

Revêtement diamant
Rivestite Diamond

Graphite / Grafite

FRAISE TORIQUE

FRESE TORICHE



pour graphite

per grafite

DSTG

3-lèvres, 40° angle d'hélice, avec rayon
3 taglienti, angolo d'elica 40°, con spigolo raggiato

recomm. conditions de coupe
page K68

Per parametri d'impiego suggeriti vd. pag. K68

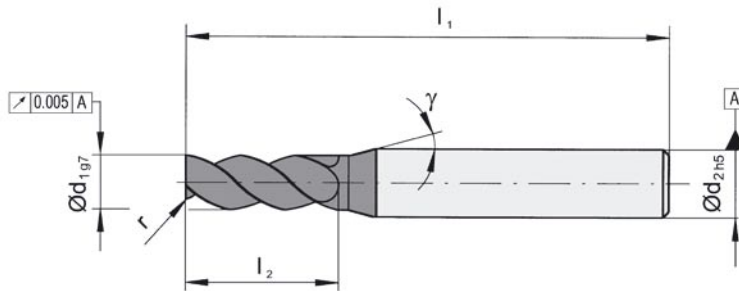

Graphite / Grafite

N° de commande Codice prodotto	d ₁	d ₂	l ₁	l ₂	r	Z	γ	CD5K
DSTG.3.02.1.50.04 DSTG.3.02.3.50.04	2	4	50	12	0,1 0,3	3	15°	• •
DSTG.3.02.1.63.06 DSTG.3.02.3.63.06	2	6	63	12	0,1 0,3	3	15°	• •
DSTG.3.03.1.50.04 DSTG.3.03.3.50.04	3	4	50	12	0,1 0,3	3	15°	• •
DSTG.3.03.1.63.06 DSTG.3.03.3.63.06	3	6	63	12	0,1 0,3	3	15°	• •
DSTG.3.04.2.63.06 DSTG.3.04.5.63.06	4	6	63	16	0,2 0,5	3	15°	• •
DSTG.3.05.2.63.06 DSTG.3.05.5.63.06	5	6	63	22	0,2 0,5	3	15°	• •

Dimensions en mm
Dimensioni in mm

Nuance recommandée
Leghe consigliate

Revêtement diamant
Rivestite Diamond

pour graphite

per grafite

DSTG

3-lèvres, 40° angle d'hélice, avec rayon
3 taglienti, angolo d'elica 40°, con spigolo raggiato

recomm. conditions de coupe
page K68

Per parametri d'impiego suggeriti vd. pag. K68

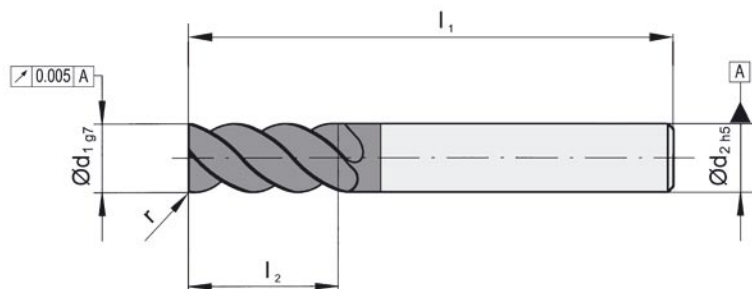

Graphite / Grafite

N° de commande Codice prodotto	d ₁	d ₂	l ₁	l ₂	r	Z	CD5K
DSTG.3.06.3.77.06	6	6	77	32	0,3	3	•
DSTG.3.06.5.77.06					0,5		•
DSTG.3.06.10.77.06					1,0		•
DSTG.3.08.3.77.08	8	8	77	32	0,3	3	•
DSTG.3.08.5.77.08					0,5		•
DSTG.3.08.10.77.08					1,0		•
DSTG.3.10.3.77.10	10	10	77	32	0,3	3	•
DSTG.3.10.5.77.10					0,5		•
DSTG.3.10.10.77.10					1,0		•
DSTG.3.12.3.77.12	12	12	77	32	0,3	3	•
DSTG.3.12.5.77.12					0,5		•
DSTG.3.12.10.77.12					1,0		•

Dimensions en mm
Dimensioni in mm

Nuance recommandée
Leghe consigliate

Revêtement diamant
Rivestite Diamond

FRAISE TORIQUE

FRESE TORICHE



pour graphite

per grafite

DSTLG

2-lèvres, 40° angle d'hélice, avec rayon
2 taglienti, angolo d'elica 40°, con spigolo raggiato

recomm. conditions de coupe
page K68

Per parametri d'impiego suggeriti vd. pag. K68

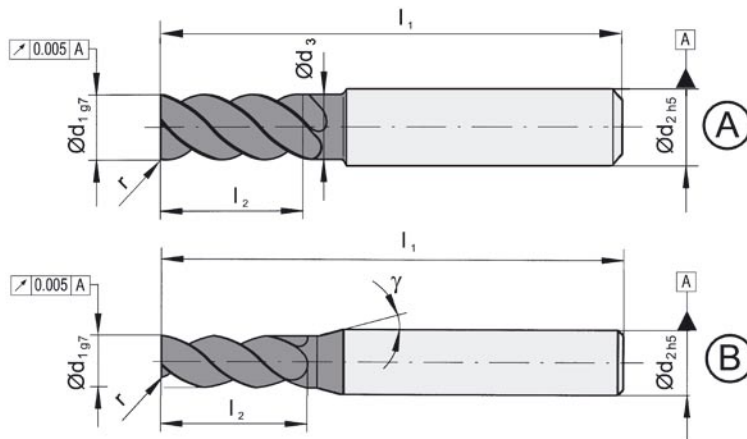

Série longue
Serie lunga

N° de commande Codice prodotto	d ₁	d ₂	d ₃	l ₁	l ₂	l ₃	r	Z	γ	Version Versione	CD5K
DSTLG.2.06.5.099.06	6	6	5,6	99	20	45	0,5	2	-	A	•
DSTLG.2.08.5.149.08	8	8	7,6	149	20	60					•
DSTLG.2.10.5.149.10	10	10	9,6	149	20	75					•
DSTLG.2.12.5.149.12	12	12	11,6	149	25	75					•
DSTLG.2.02.3.099.04	2	4	1,9	99	5	10	0,3	2	15°	B	•
DSTLG.2.03.3.099.04	3	4	2,9		8	15					•
DSTLG.2.04.3.099.06	4	6	3,8		15	30					•

Dimensions en mm
Dimensioni in mm

Nuance recommandée
Leghe consigliate

Revêtement diamant
Rivestite Diamond

Graphite / Grafite

FRAISE D'EBAUCHE

FRESE PER SGROSSATURA



pour graphite
per grafite

DSVG

multi-dents
Multitaglienti

recomm. conditions de coupe
page K69
Per parametri d'impiego suggeriti vd. pag. K69

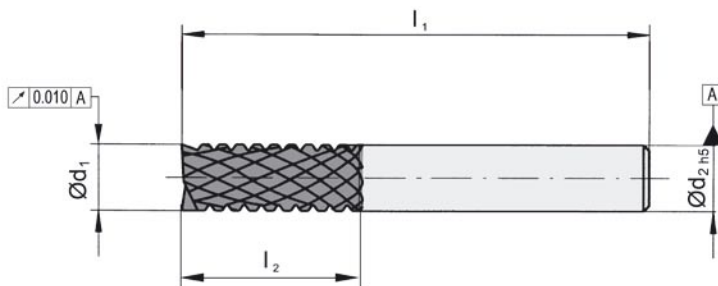

Graphite / Grafite

N° de commande Codice prodotto	d ₁	d ₂	l ₁	l ₂	CD5K
DSVG.X.04.0.59.04	4	4	59	12	•
DSVG.X.06.0.77.06	6	6	77	18	•
DSVG.X.08.0.77.08	8	8	77	24	•
DSVG.X.10.0.77.10	10	10	77	30	•
DSVG.X.12.0.88.12	12	12	88	36	•

Dimensions en mm
Dimensioni in mm

Nuance recommandée
Leghe consigliate

Revêtement diamant
Rivestite Diamond

MICROFRAISE HEMISPHERIQUE

MICROFRESE RAGGIO COMPLETO



pour graphite

per grafite

DSKMG

2-lèvres, angle d'hélice 40°
2 taglienti, angolo d'elica 40°

recomm. conditions de coupe
page K70

Per parametri d'impiego suggeriti vd. pag. K70

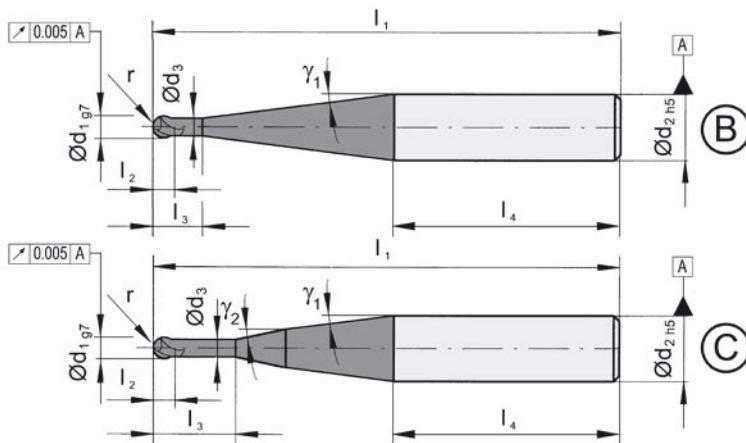

Graphite / Grafite

N° de commande Codice prodotto	d ₁	d ₂	l ₁	l ₂	l ₃	l ₄	d ₃	r	Z	γ ₁	γ ₂	Version Versione	CD5K
DSKMG.2.03.50.4.L40	0,3			2,0	4		0,25	0,15		10,6°			•
DSKMG.2.04.50.4.L50	0,4			2,0	5		0,35	0,20		11,5°			•
DSKMG.2.05.50.4.L40	0,5			2,0	4		0,45	0,25		10,1°			•
DSKMG.2.05.50.4.L60	0,5			2,0	6		0,45	0,25		12,5°			•
DSKMG.2.06.50.4.L70	0,6	4	50	2,5	7	36	0,55	0,30	2	13,8°		B	•
DSKMG.2.08.50.4.L80	0,8			2,5	8		0,75	0,40		15,2°			•
DSKMG.2.10.50.4.L10	1,0			3,5	10		0,90	0,50		21,2°			•
DSKMG.2.10.50.4.L60	1,0			3,5	6		0,90	0,50		11°			•
DSKMG.2.15.50.4.L10	1,5			3,5	10		1,40	0,75		18°			•
DSKMG.2.05.63.6.L40	0,5			2,0	4		0,45	0,25		9,5°			•
DSKMG.2.05.63.6.L60	0,5			2,0	6		0,45	0,25		11°			•
DSKMG.2.10.63.6.L10	1,0	6	63	2,5	10	40	0,90	0,50	2	14,8°	5	C	•
DSKMG.2.10.63.6.L60	1,0			3,5	6		0,90	0,50		10°			•
DSKMG.2.15.63.6.L10	1,5			3,5	10		1,40	0,75		13,1°			•

Dimensions en mm
Dimensioni in mm

Nuance recommandée
Leghe consigliate

Revêtement diamant
Rivestite Diamond

MICROFRAISE multi dents MICROFRESE MULTITAGLIANTI



pour graphite

per grafite

DSMMG

2-lèvres, 40° angle d'hélice, avec rayon
2 taglienti, angolo d'elica 40°, con spigolo raggiato

recomm. conditions de coupe
page K71

Per parametri d'impiego suggeriti vd. pag. K71

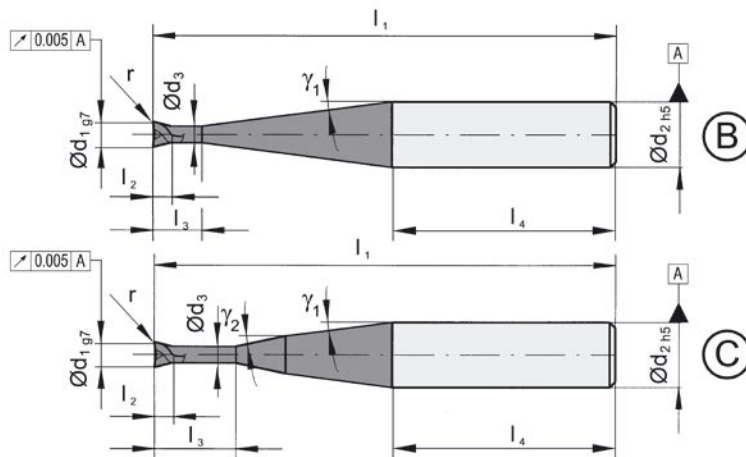

Graphite / Grafite

N° de commande Codice prodotto	d ₁	d ₂	l ₁	l ₂	l ₃	l ₄	d ₃	r	Z	γ ₁	γ ₂	Version Versione	CD5K
DSMMG.2.03.50.4.L40	0,3			2,0	4		0,25			10,6°			•
DSMMG.2.04.50.4.L50	0,4			2,0	5		0,35			11,5°			•
DSMMG.2.05.50.4.L40	0,5			2,0	4		0,45			10,1°			•
DSMMG.2.05.50.4.L60	0,5			2,0	6		0,45			12,5°			•
DSMMG.2.06.50.4.L70	0,6	4	50	2,5	7	36	0,55	0,05	2	13,8°	0°	B	•
DSMMG.2.08.50.4.L80	0,8			2,5	8		0,75			15,2°			•
DSMMG.2.10.50.4.L10	1,0			3,5	10		0,90			21,2°			•
DSMMG.2.10.50.4.L60	1,0			3,5	6		0,90			11°			•
DSMMG.2.15.50.4.L10	1,5			3,5	10		1,40			18°			•
DSMMG.2.05.63.6.L40	0,5			2,0	4		0,45			9,5°			•
DSMMG.2.05.63.6.L60	0,5			2,0	6		0,45			11°			•
DSMMG.2.10.63.6.L10	1,0	6	63	3,5	10	40	0,90	0,05	2	14,8°	5°	C	•
DSMMG.2.10.63.6.L60	1,0			3,5	6		0,90			10°			•
DSMMG.2.15.63.6.L10	1,5			3,5	10		1,40			13,1°			•

Dimensions en mm
Dimensioni in mm

Nuance recommandée
Leghe consigliate

Revêtement diamant
Rivestite Diamond