

HORN - LÀ OU LES AUTRES S'ARRÊTENT

HORN - LEADER NELLA TECNOLOGIA DELLE GOLE



NOUVEAU
NOVITÀ

Filetage par tourbillonnage avec fraises type M302 pour machine Swiss

Fresa per turbofilettatura
tipo M302 per macchine utensili
a fantina mobile



- GORGE
 - GOLE
- TRONÇONNAGE
 - TRONCATURA
- FRAISAGE
 - FRESATURA
- BROCHAGE
 - BROCCIATURA
- COPIAGE FRAISAGE
 - PROFILATURA IN FRESATURA
- PERÇAGE
 - FORATURA

ph HORN ph

HORN S.A.S.
665, Avenue Blaise Pascal
Zone Industrielle
77127 Lieusaint
Tél.: 01 64 885 958
Fax: 01 64 886 049
infos@horn.fr
www.horn.fr



Système modulaire:

La solution pour le changement d'outil dans des conditions d'encombrements limitées. Le corps de l'outil reste sur la machine, le support de plaquettes est enlevé avec l'écrou de sécurité. Les plaquettes amovibles peuvent être facilement remplacées hors de la machine.

Sistema modulare:

Soluzione per il cambio inserti in spazio ridotto. Il corpo base rimane sulla macchina, mentre il corpo fresa invece si può rimuovere tramite lo smontaggio della ghiera di estrazione. In questo modo si possono cambiare agevolmente gli inserti fuori macchina.

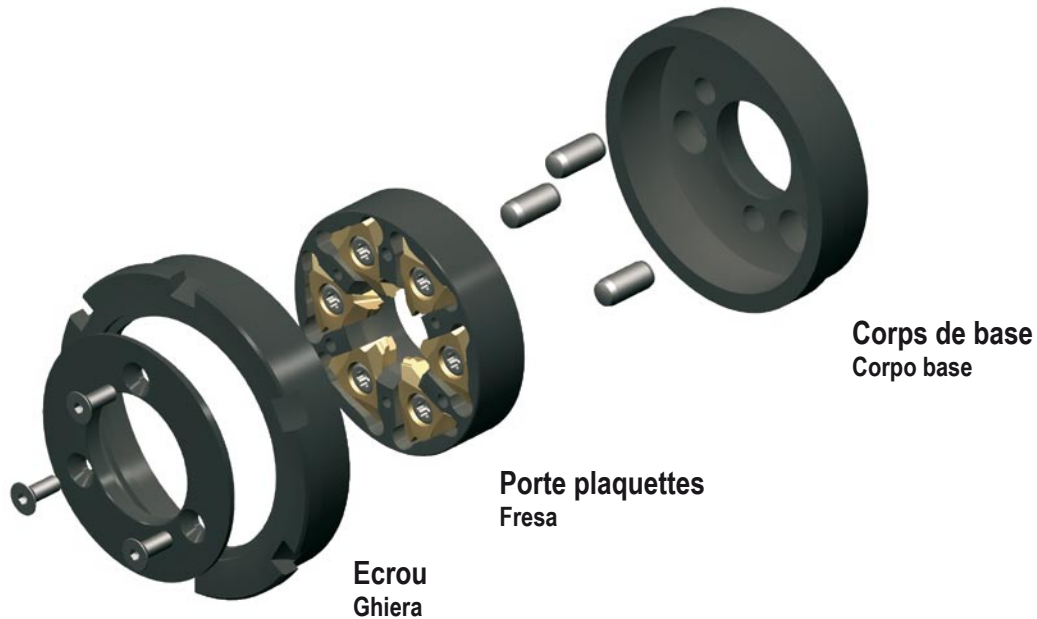

Système Monobloc:

Précision et stabilité maximale

Sistema Monoblocco:

Il massimo per precisione e stabilità



Plaquettes à tourbillonner:

Inserti a turbofilettare:



Un filet

Profilo a un principio



Double filet

Profilo a due principi



Double filet

Profilo a due principi

Plaquette Type 302

Profondeur de formes jusqu'à t = 4,3 mm

Largueur de formes w = 4,4 / 5,4 / 6,1 mm

Inserti Tipo 302

Profondità di forma fino a

t = 4,3 mm

Larghezza di forma fino a

w = 4,4 / 5,4 / 6,1 mm

Plaquette Type 314

Profondeur de formes jusqu'à t = 5,0 mm

Largueur de formes w = 5,4 / 6,5 / 7,5 mm

Inserti Tipo 314

Profondità di forma fino a

t = 5,0 mm

Larghezza di forma fino a

w = 5,4 / 6,5 / 7,5 mm

TÊTE À TOURBILLONNER Type M302 / 389

FRESA A TURBOFILETTARE Tipo M302 / 389

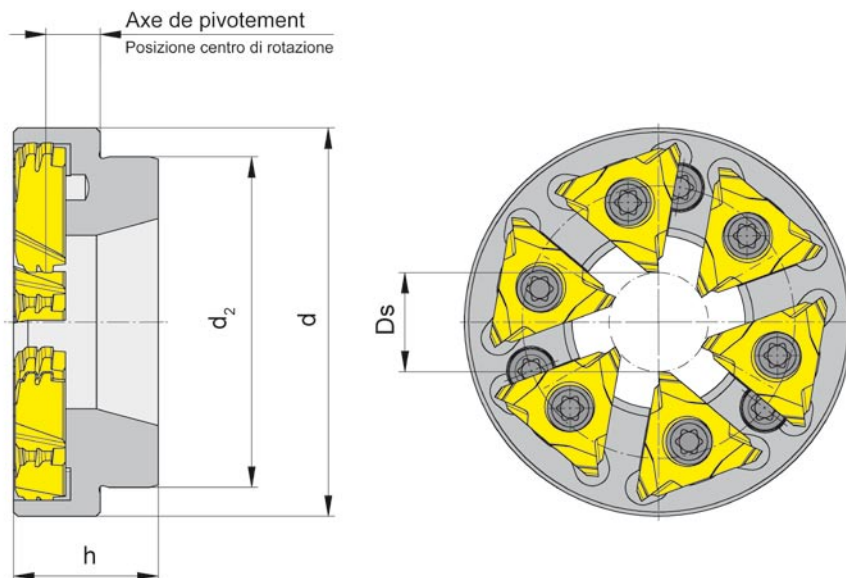

N° de commande Codice prodotto	*Axe de pivotement * Posizione centro di rotazione	Z	Ds	d	h	d ₂	Plaquelette Inserti	Type de machine Tipo di macchina
Outils standards (stock) Utensili standard (a stock)								
L389.D014.40.06	12,750	6	14,0	57,2	21,0	40,000	314	Tornos Deco 2000/20a
M302.T025.54.06	11,000		25,0	106,0	24,1	53,975	S302	Traub TNL 26
M302.T010.37.06	6,700		10,0	73,55	16,5	36,990	S302	Traub TNL 12
M302.C012.40.06	11,000		12,0	46,0	17,0	45,000	S302	Citizen Cincom M16
M302.A012.40.06	6,575		12,0	47,0	17,5	40,000	S302	Star SV/SR20/ECAS20
Outils spéciaux (délai 6 semaines) Utensili Speciali (consegna 6 settimane)								
M302.0013.0124	6,700	6	13,5	62,0	18,0	62,000	S302	{ Gildemeister Speed 20/8; 20/11 Gildemeister Sprint 20/8 }
M302.0015.0153	9,775		13,5	49,0	15,0	42,500		

* L'axe de pivotement dépend du profil des plaquettes
* Il profilo dell'inserto è vincolato al centro di rotazione

Dimensions en mm
Dimensioni in mm

TÊTE À TOURBILLONNER Type M302 / 006
FRESA A TURBOFILETTARE Tipo M302 / 006

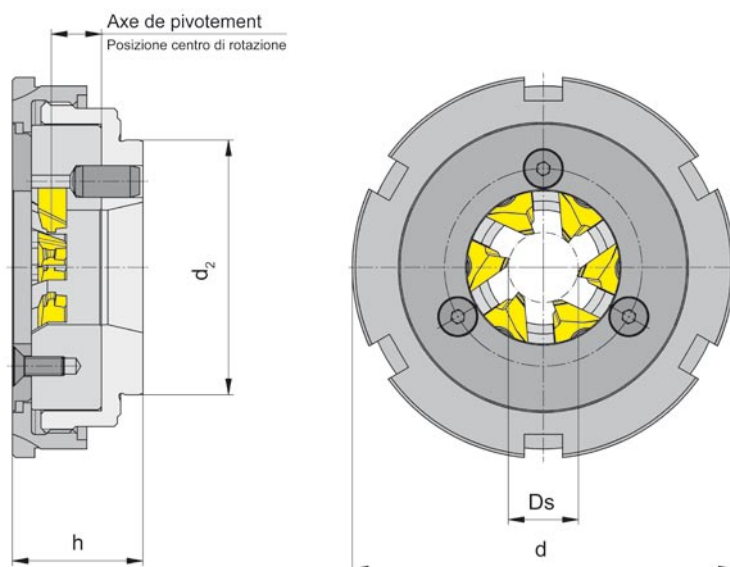

N° de commande Codice prodotto	*Axe de pivotement * Posizione centro di rotazione	Z	Ds	d	h	d ₂	Plaquette Inserti	Type de machine Tipo di macchina
Outils standards (stock) Utensili standard (a stock)								
M302.AM012.40.06	11,900	6	12,0	47 (52)	20,7	40,000	S302	Star SV12/20ECAS20
M302.DM11.0.40.06	7,800		11,0	60,0	20,5	40,000	S302	Tornos Deco 2000/13a/20
M302.AM12.T.40.06	5,000		12,0	60,0	17,0	40,000	S302	Star SR20III
Outils spéciaux (délai 6 semaines) Utensili Speciali (consegna 6 settimane)								
006.0050.1348	15,000	6	14,0	67,0	18,0	50,000	S302	Traub TNL 26

* L'axe de pivotement dépend du profil des plaquettes

* Il profilo dell'inserto è vincolato al centro di rotazione

Dimensions en mm

Dimensioni in mm